

Selective Sterilization of *Vibrio parahaemolyticus* from a Bacterial Mixture by Low-Amperage Electric Current

Jin, Soo Chang^{1,2}, Hyunsuk Yoo^{1,3}, Yeon I. Woo^{1,2}, Mi Hee Lee^{1,2}, Barbora Vagaska^{1,2}, Jung-Sung Kim^{1,2}, Masakazu Uzawa⁴, and Jong-Chul Park^{1,2*}

¹Department of Medical Engineering and ²Brain Korea 21 Project for Medical Science, Yonsei University College of Medicine, Seoul 120-752, Korea

³Korean Minjok Leadership Academy, Gangwon-do 225-823, Korea

⁴Applied Science Co. Ltd., Ichikawa-si, Chiba 272-0822, Japan

Received: July 2, 2008 / Revised: September 19, 2008 / Accepted: October 22, 2008

The objective of this study was to investigate the possibility of using low-amperage electrical treatment (LAET) as a selective bactericide. Mixtures containing *Escherichia coli*, *Staphylococcus aureus*, and *Vibrio parahaemolyticus* were treated with different electric current intensities and for different times. The results showed that at 263 mA, treating bacteria for 100 ms eliminated all *V. parahaemolyticus* colonies. Although LAET reduced the populations of the three microorganisms, *V. parahaemolyticus* was more injured by LAET than *S. aureus* and *E. coli* when treated at the same processing conditions.

Keywords: *Escherichia coli*, low-amperage electrical treatment, *Staphylococcus aureus*, selective sterilization, *Vibrio parahaemolyticus*

The need to distinguish between useful and useless microorganisms is increasing. To make use of fermentation in food industries, pure microorganism cultures are required, and therefore undesirable bacteria need to be selectively eliminated. Chemical sterilization is the generally used method in the industries. However, the leftover chemical substances may be toxic, can deteriorate, and can cause unnecessary resistance in bacteria [4]. Pathogenic microorganisms can be easily eliminated through heat, but sensorial and nutritional attributes are extensively damaged [7]. Ozone treatment and radiation sterilization, using X-rays, gamma-rays, or ultraviolet (UV) rays are costly [8, 11]. Among other methods, low-amperage electrical treatment (LAET) is being given special interest. This method could be applied to these industries. The electrical breakdown or disruption of biological membranes in a low-amperage electrical treatment is a well-known

phenomenon[3], which can be explained relatively easily by electromechanical compression. The process consists of applying electric currents (0–1,000 mA) for a short period of time (0–2,000 ms) to electric vessels that are placed in between the electrodes [10]. Since low-amperage treatments may be able to inactivate bacteria by causing irreversible damage to the cellular membrane, it could be used to complement the conventional methods. Moreover, since most of the conventional methods use intense chemical or physical conditions to kill bacteria, they may affect other useful microorganisms that need to be kept alive for the success of the industries. LAET is potentially more useful because the method avoids intense chemical treatments and uses reduced physical conditions [3].

This study chose *Vibrio parahaemolyticus* to test the possibility of selective removal by LAET. *V. parahaemolyticus* was chosen because the bacterium is responsible for causing diarrhea and acute gastroenteritis, and therefore has to be removed for food making. The aims of this study were to evaluate the effect of the treatment time and electric current, as variable parameters of LAET, on *Staphylococcus aureus*, *Escherichia coli*, and *V. parahaemolyticus* populations inoculated in solution, as well as to obtain optimized values of these processing factors for the standardization of the LAET.

The strain of *V. parahaemolyticus* (ATCC17802) was cultured in nutrient broth (Difco, Detroit, U.S.A.) containing 15% (wt/vol) agarose and 3% (wt/vol) NaCl. One ml of each overnight culture was inoculated in 50 ml of nutrient broth containing 3% (wt/vol) NaCl and incubated without agitation for 18 h at 37°C to obtain cells in the early stationary growth phase. The *V. parahaemolyticus* was resuspended in saline solution (0.9% NaCl). *E. coli* (ATCC 8739) and *S. aureus* (ATCC 6358P) were cultured in standard method agar (Difco). One ml of each overnight culture was inoculated in 50 ml of Tryptic Soy Broth

*Corresponding author

Phone: +82 2 2228 1917; Fax: +82 2 363 9923;

E-mail: parkjc@yuhs.ac

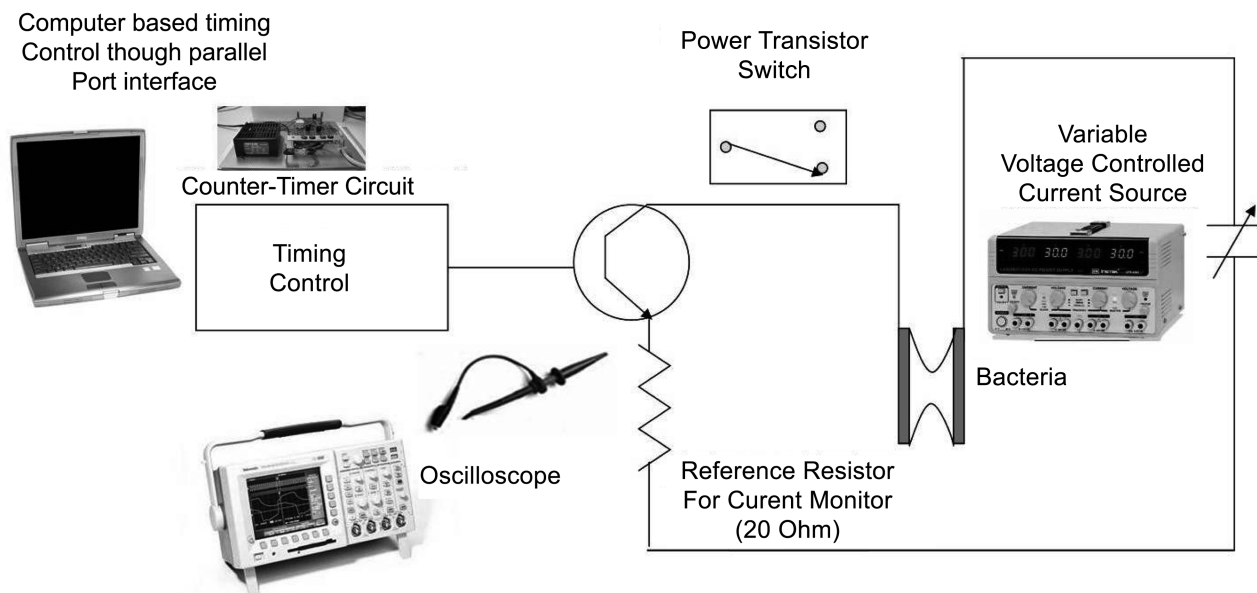

Fig. 1. The experimental configuration.

(TSB) and incubated without agitation for 14 h at 37°C to obtain cells in the early stationary growth phase. The bacteria were resuspended in saline solution (0.9% NaCl). After the bacterial solutions were made, they were inoculated in 2.5 ml of saline solution to a density of 10^6 CFU/ml prior to transferring into an electrolysis vessel.

As previously described [10], the equipment of LAET with computer-based timing control through a parallel port interface was used to control the power transistor (K2967; Toshiba, Tokyo, Japan) and hence the time of the treatment. To determine the amperage of the current applied to the bacterial solution, a reference resistor of 20 Ω was monitored; an oscilloscope (Tektronix 2445; Tektronix Co, Portland, U.S.A.) measured the voltage applied to the reference resistor. The reference resistor was connected in series with the electrolysis vessel, which was made as a small-batch treatment prototype and had two platinum electrodes (5 mm wide, 50 mm long) that were 3.5 mm apart from each other, with enough volume to contain 2.5 ml of solution. The power for the experiment was supplied by the variable voltage controlled current source (DRP-9303 TP; Digital Electronics Co, Inchon, Korea) (Fig. 1).

The effects of low-amperage electric current were studied by treating the *S. aureus* solutions with direct current of 8.3 mA, 42 mA, 83 mA, 263 mA, and 526 mA. After the treatment, the solutions were diluted to the concentration of 10^2 CFU for the ease of colony counting. LAET was carried out in duplicate with 2.5 ml of the same concentration of *E. coli*, *S. aureus*, and *V. parahaemolyticus* in saline solution and the results shown are expressed as the mean \pm standard deviation. The detection limit of this procedure was 5 CFU/ml.

The electric vessels were treated at the time durations of 10 ms, 50 ms, 100 ms, 500 ms, 1,000 ms, and 2,000 ms at five different amperes by which it was confirmed that LAET did not generate Cl_2 gas, except at 2,000 ms.

After the bacteria were given electric field treatments, *S. aureus* and *E. coli* were grown in the standard method agar, and colonies of *V. parahaemolyticus* were grown in nutrient broth containing 3% NaCl, 15% agarose at 37°C for 48 h. Then, the bacterial colonies were counted.

To test that this study confirmed selectivity, a solution that contained 10^6 CFU of *E. coli*, *S. aureus*, and *V. parahaemolyticus* was made. Before making the mixture, the microbes were resuspended in saline solution (0.9% NaCl). The mixed solution was treated at 263 mA for 100 ms because, at this point, the maximum difference of bacterial viability rate was shown among the three bacteria. After the mixed solution was treated with LAET, the bacteria were grown in selective agars: mannitol salt agar (*S. aureus*) (Difco), sorbitol Mac Carey agar (*E. coli*) (Difco), and TCBS (Thiosulfate Conkey BIIO Sucrose) agar (*V. parahaemolyticus*) (Difco) at 37°C for 48 h. After the incubation, pictures were taken to verify differences in bacterial survival.

The morphology of bacteria treated without or with LAET was observed under a scanning electron microscope (Hitachi S-800, Tokyo, Japan). The films were mounted and sputter-coated with gold/platinum using an ion coater (E1010, Hitachi) and then observed at an accelerating voltage of 20 kV.

At 526 mA, all bacteria died regardless of treatment time; at 8.3 mA and 42 mA, Fig. 2A shows that no great bacterial colony decrease was observed. In the intermediate currents, the treatment showed selectivity. Figs. 2B and 2C

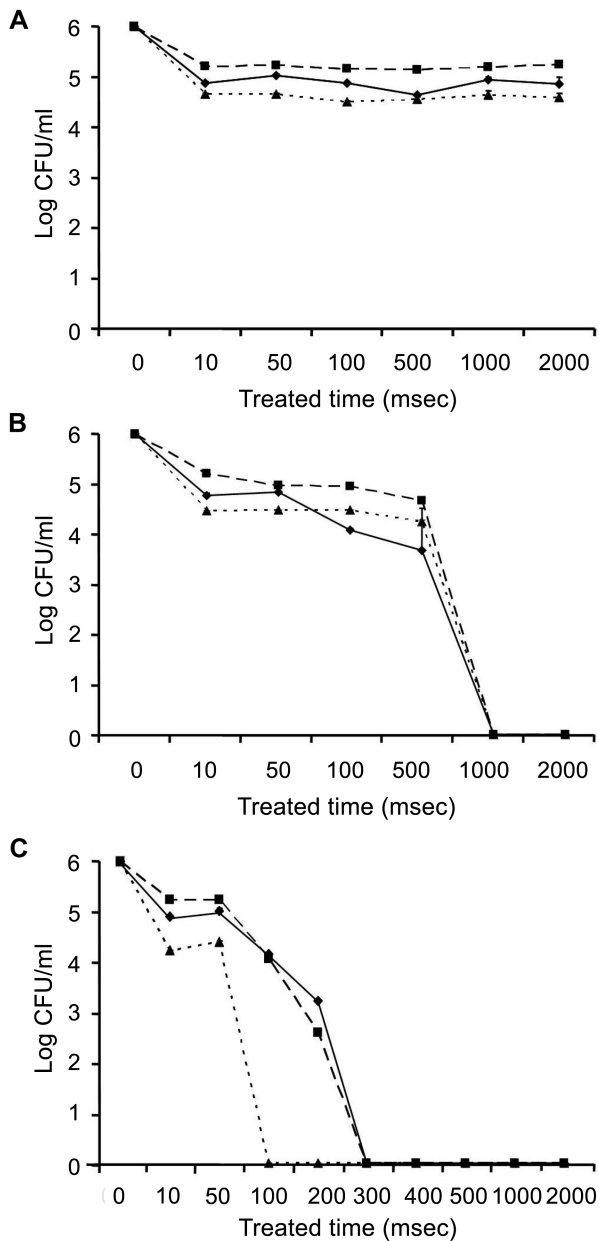

Fig. 2. Effect of low-amperage electrical treatment on lethality of *E. coli* (■), *S. aureus* (◆), and *V. parahaemolyticus* (▲) induced by electrolysis at (A) 8.3 mA, (B) 83 mA, and (C) 263 mA in 0.9% NaCl solution.

show that the number of bacterial colonies decreased proportionally to the applied electricity time. The bacterial colony reduction was different for the three bacteria.

In Fig. 2B (at 83 mA), the rate differences were not significant. However, the Fig. 2C (at 263 mA), the *V. parahaemolyticus* survival rate was conspicuously different from the other two bacteria; *E. coli* and *S. aureus* behaved similarly in both 83 mA and 263 mA. Fig. 2C shows that *V. parahaemolyticus* was completely killed after 100 ms of electric treatment, whereas the other two bacteria survived.

This meant that *V. parahaemolyticus* could selectively be killed while leaving *E. coli* and *S. aureus* alive.

A solution that contained 10^4 CFU/ml of the three bacteria was made and then treated with 263 mA for 100 ms. Fig. 3 shows the bacterial colonies after the treated bacteria were incubated. Figs. 3B and 3D show that while the number of colonies of *E. coli* and *S. aureus* decreased after the treatment, the number of *V. parahaemolyticus* colonies was eliminated.

These results were then confirmed by SEM micrographs showing the morphology of microbial cultures without or with LAET (Fig. 4). The morphology of microbial control is shown in Figs. 4A and 4C, and 4E. In contrast figure of microbes treated with LAET show that pores were made in the bacteria membrane and the natural morphology of *V. parahaemolyticus* has changed (Fig. 4F).

Both the quantitative colony counts and the growth on selective agars showed the consistent result that *V. parahaemolyticus* can be selectively killed while leaving *E. coli* and *S. aureus* alive.

The result was different from that of García *et al* [2, 6], who showed that Gram-positive bacteria have a higher pulsed electric field (PEF) resistance. However, in this experiment, *V. parahaemolyticus*, a Gram-negative bacterium, behaved similarly to *S. aureus*, a Gram-positive bacterium. It cannot be postulated that a Gram-negative bacterium is inactivated first by electric treatment, in accordance with this study's results.

There is no established theory on why the bacteria are inactivated by the applied electric current. One possible mechanism is irreversible electroporation. The model considers the membrane as a viscoelastic fluid that is ruptured because of electric stress [1].

Another mechanism is related to the change in the membrane potential of bacteria. According to Weaver [12], when an electric field is applied, a part of the membrane undergoes a "flip" in potential, disturbing the cell signaling that is maintained by the concentration gradients of sodium and potassium ions. This ionic imbalance leads to improper cell function and cell death. These mechanisms indicate that the selective bactericide is possible as the membranes of microorganisms are all different [9].

In our study, influence of very low electric currents by LAET on the *V. parahaemolyticus* inactivation in solution and mixture was observed. One possible use of the result of this study is applying it in removing undesirable microorganisms that hinder the process of fermentation. In making recombinant *E. coli* [5], companies are having difficulties maintaining the purity of the microbes because they are easily contaminated by another bacteria. If adequate conditions are found in which the contaminants may be eliminated by LAET, the specific microbe could be purified without much harm being done to them. Moreover, since the electricity is applied for milliseconds, it is much more

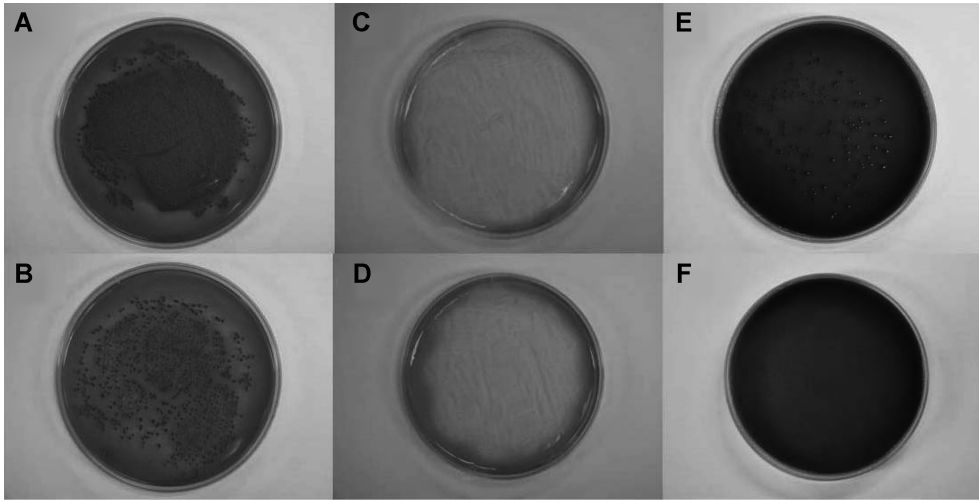

Fig. 3. Growth of mixed solution [10^4 CFU/ml of *S. aureus* **A, B** (sorbitol Mac Conkey agar), *E. coli* **C, D** (mannitol salt agar), and *V. parahaemolyticus* **E, F** (Thiosulfate Citrate BIIO Sucrose agar)] treated at 263 mA for 100 ms: without LAET **A, C, E**, and with LAET **B, D, F**.

practical and safer than conventional methods. The method is also being developed to be used in the medicine industry and in electric therapy.

More studies need to be done to elucidate which variables may affect the membrane's susceptibility to the applied electrical treatments.

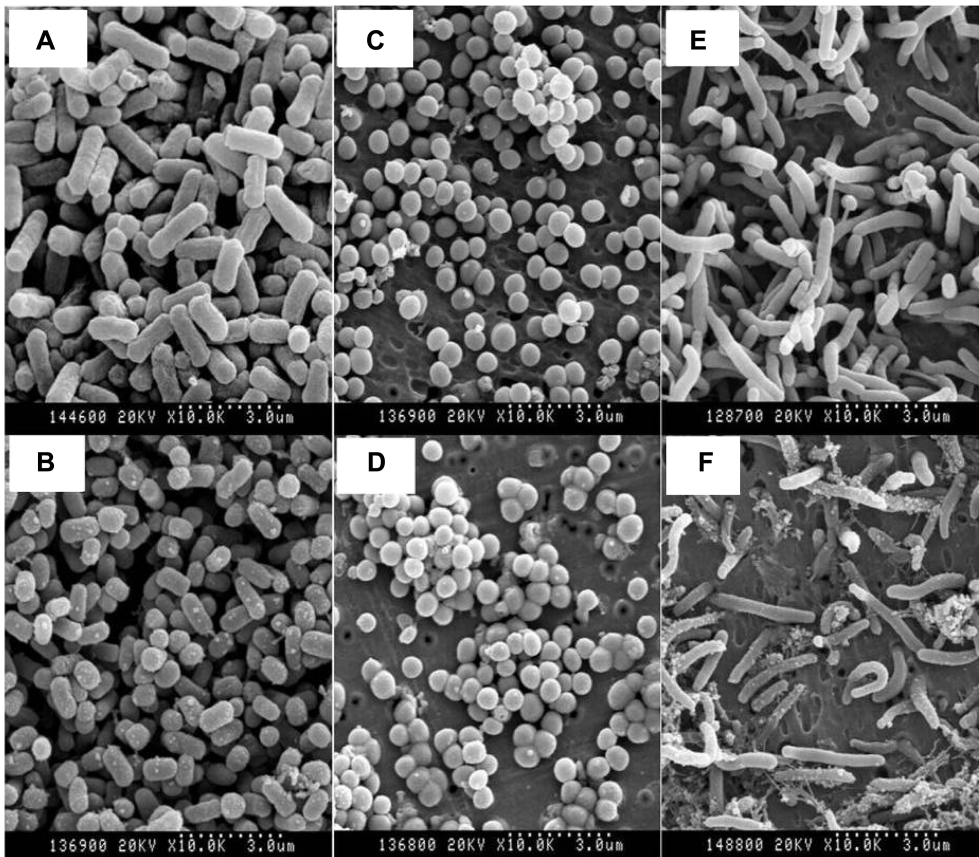

Fig. 4. SEM micrographs of *E. coli* (left panels), *S. aureus* (middle panels), and *V. parahaemolyticus* (right panels), in 0.9% NaCl solution treated without (**A, C, E**) or with (**B, D, F**) low-amperage electrical treatment for 100 ms at 263 mA.

Acknowledgment

This work was supported by the Korea Science and Engineering Foundation (KOSEF, Grant No. R01-2007-000-20472-0).

REFERENCES

1. Dimitrov, D. S. and R. K. Jain. 1984. Membrane stability. *Biochim. Biophys. Acta* **779**: 437–468.
2. García, D., N. Gómez, P. Mañas, S. Condón, J. Raso, and R. Pagán. 2005. Occurrence of sublethal injury after pulsed electric fields depending on the micro-organism, the treatment medium pH and the intensity of the treatment investigated. *J. Appl. Microbiol.* **99**: 94–104.
3. Guillou, S. and N. El Murr. 2002. Inactivation of *Saccharomyces cerevisiae* in solution by low-amperage electric treatment. *J. Appl. Microbiol.* **92**: 860–865.
4. Hatha, A. A. and P. Lakshmanaperumalsamy. 1995. Antibiotic resistance of *Salmonella* strains isolated from fish and crustaceans. *Lett. Appl. Microbiol.* **21**: 47–49.
5. Kim, S.-Y., C.-H. Lee, K.-J. Kim, and Y.-S. Kim. 2001. Expression of the functional recombinant interleukin-16 in *E. coli* and mammalian cell lines. *J. Microbiol. Biotechnol.* **11**: 234–241.
6. Lvarez, A., R. Pagán, J. Raso, and S. Condón. 2002. Environmental factors influencing the inactivation of *Listeria monocytogenes* by pulsed electric fields. *Lett. Appl. Microbiol.* **35**: 489–493.
7. Mann, A., M. Kiefer, and H. Leuenberger. 2001. Thermal sterilization of heat-sensitive products using high-temperature short-time sterilization. *J. Pharm. Sci.* **90**: 275–287.
8. Miller, C. M. and R. L. Valentine. 1995. Oxidation behavior of aqueous contaminants in the presence of hydrogen peroxide and filter media. *J. Hazard. Mater.* **41**: 105–116.
9. Mosqueda-Melgar, J., R. M. Raybaudi-Massilia, and O. Martín-Belloso. 2007. Influence of treatment time and pulse frequency on *Salmonella enteritidis*, *Escherichia coli* and *Listeria monocytogenes* populations inoculated in melon and watermelon juices treated by pulsed electric fields. *J. Food Microbiol.* **117**: 192–200.
10. Park, J.-C., M. S. Lee, D. W. Han, D. H. Lee, B. J. Park, I.-S. Lee, M. Uzawa, M. Aihara, and K. Takatori. 2004. Inactivation of bacteria in seawater by low-amperage electric current. *Appl. Environ. Microbiol.* **70**: 2405–2408.
11. Smith, R. J., S. C. Kehoe, K. G. McGuigan, and M. R. Barerl. 2000. Effect of simulated solar disinfection of water on infectivity of *Salmonella typhimurium*. *Lett. Appl. Microbiol.* **31**: 284–288.
12. Weaver, J. C. 1995. Electroporation theory: concepts and mechanisms, pp. 1–26. In Nickoloff, J. A. (ed.), *Electroporation Protocols for Microorganisms*. Humana Press, Totowa, New Jersey.